

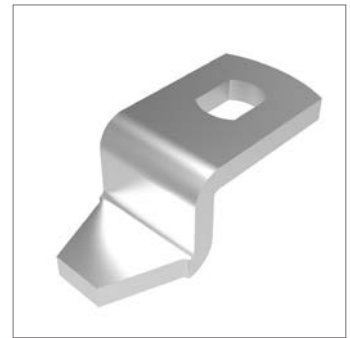

Single Point Cams - Steel

for adjustable grip compression cam latches

Latches

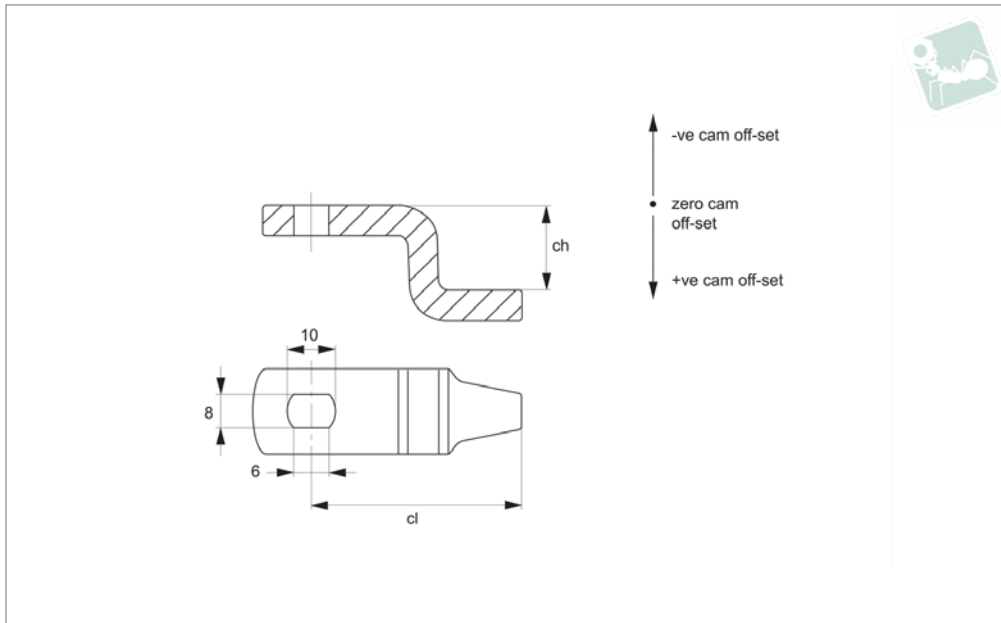

CC0030

LATCHES

Material

Steel, zinc plated.

Technical Notes

Use formula to calculate ch (required cam off-set), and select from product table below;

$ch = h - lh$ where;

ch = required cam off-set/height.

h = grip length (distance between inside of

latch face and front of cam).

lh = body length of cam latch/lock to be used (see individual latch/lock product table).

Refer to installation drawing below.

Important Notes

Suitable for adjustable grip compression cam latches CC0802, CC0810, , .

See cam selection chart for specific

latch/lock suitability.

Installation hole is rectangular 6mmx4mm.

Please note due to design of the single point cam, it is not possible to use +ve offset cam in reverse/upside down as it results in a clash with the body of the cam latch- making it inoperable.

Order No.	ch	cl	Where $lh = 32$
CC0030.M0300	0	33	32
CC0030.M0314	14	33	46
CC0030.M0327	27	33	59

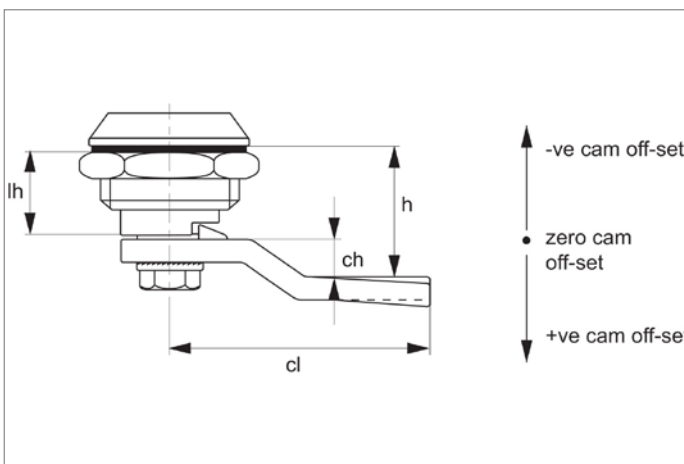



Suitable With Projection Cams				
Compatible cam no.	A0261	A0203	A0210	A0240
Cam fitting hole	6 x 6 square 	8 x 8 square 	8 x 8 square 	8 x 8 square
Cam latch / lock no.	A1261 / A1281 / A2390	A2503 / A2504 A2523 / A2528	A2503 / A2504 A2523 / A2528	A2503 / A2504 A2523 / A2528

Suitable Without Projection Cams Table 1				
Compatible cam no.	A0203	A0210	A0240	A0243
Cam fitting hole	8 x 8 square 	8 x 8 square 	8 x 8 square 	8 x 8 square
Cam latch / lock no.	A1003 / A1021 / A1103 A1161 / A1168 / A1181 A1203 / A1210 / A1251 A1601 / A1620 / A1801 A2001 / A2203 / A2326 A2333 / A2392 / A2526 A4221 / A4241 / A4260 B1082 / B1086 / B1088 B1091 / B1092 / B1180 B1281 / B1285 / B1380 B1450 / B2091 / B2181	A1003 / A1021 / A1103 A1161 / A1168 / A1181 A1203 / A1210 / A1251 A1601 / A1620 / A1801 A2001 / A2203 / A2326 A2333 / A2392 / A2526 A4221 / A4241 / A4260 B1082 / B1086 / B1088 B1091 / B1092 / B1180 B1281 / B1285 / B1380 B1450 / B2091 / B2181	A1003 / A1021 / A1103 A1161 / A1168 / A1181 A1203 / A1210 / A1251 A1601 / A1620 / A1801 A2001 / A2203 / A2326 A2333 / A2392 / A2526 A4221 / A4241 / A4260 B1082 / B1086 / B1088 B1091 / B1092 / B1180 B1281 / B1285 / B1380 B1450 / B2091 / B2181	A1003 / A1021 / A1103 A1161 / A1168 / A1181 A1203 / A1210 / A1251 A1601 / A1620 / A1801 A2001 / A2203 / A2326 A2333 / A2392 / A2526 A4221 / A4241 / A4260 B1082 / B1086 / B1088 B1091 / B1092 / B1180 B1281 / B1285 / B1380 B1450 / B2091 / B2181

Suitable Without Projection Cams Table 2					
Compatible cam no.	A0250	A0234	A0215	A0231	A0233
Cam fitting hole	5 x 5 square 	6,3 dia. x 4,9 	7 x 7 square 	8 x 10 dia. 	8 x 10 dia.
Cam latch / lock no.	A4600 / A4620	A1661 / A1667	B2082 / B2084 / B2086 B2088 / B2285 / B2380	A1603 / A1611 A1630 / A1810	A1603 / A1611 A1630 / A1810

Calculation of correct cam off-set

Cam off-set

Use the formula to calculate your correct cam off-set:

$$ch = h - lh$$

ch = the required cam off-set.

h = distance between inside of lock face and front of cam (also referred to as "grip length").

lh = length of cam body to be used (refer to individual cam body data sheets).

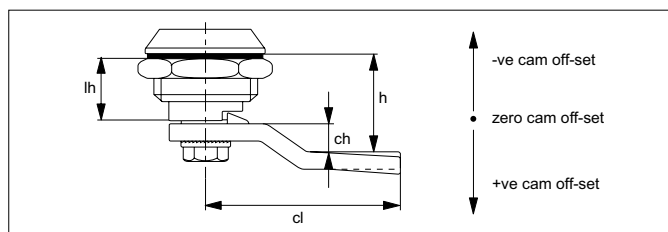

Cam Off-Set (dimension ch)

To ensure your cam fully and correctly engages with the frame of your door the correct cam off-set must be selected. A cam off-set can be either negative (-ve) or positive (+ve).

Cam Length (dimension cl)

Impacts reach of the cam to door frame and hence impacts positioning of cam body for installation. Cam length or reach is measured from the centre of the cam fixing hole to the cam's leading edge. Refer to individual cam body datasheets.